



# M312

## Wheel Excavator

**CAT**<sup>®</sup>

Cat<sup>®</sup> 3054 TA Engine

85 kW/114 hp

Operating Weight

13 220 to 14 750 kg

Bucket Capacities

0.24 to 0.86 m<sup>3</sup>

Maximum

Reach at Ground Level

9220 mm

Digging Depth

6000 mm

Travel Speed

34 km/h

# The Cat M312 wheel excavator

*Setting a high standard in mobility, versatility, operator comfort and ease of maintenance.*

---

## The 300 Family sleek styling on wheels

Both the cab and body have smooth, rounded contours with blended-in roading lights for a modern look. The cab interior combines modern styling with a soft and pleasing color scheme. The M312 offers everything an operator could expect today in a wheel excavator.

---

## A step forward in environmental considerations

The Caterpillar 3054 TA engine meets regulatory emissions requirements worldwide, including the European Union Non-Road Mobile Machinery Engine Emission Directive 97/68/EC. The engine has low spectator and operator sound levels and the hydraulic system can be operated with bio-degradable oil as an option. These features make the M312 a friendly machine, which helps protect the environment. **pg. 8**



---

### State-of-the-art hydraulic system

The load-sensing hydraulic system with load independent flow distribution offers exceptional operation control, modulation, and multi-function capability. Up to four additional hydraulic functions can be added for maximum application flexibility. **pg. 10**

---

### Modern electronics

A microprocessor together with modern electronics register the operator's commands and manage the engine and pump interface to help maximize fuel efficiency. **pg. 6-7**

---

### Ground level maintenance

All daily maintenance points are accessible from ground level. A centralized greasing port is located on the right foot of the boom. This allows the operator to grease the front linkage pins from ground level. **pg. 10**

---

### A choice of the best boom and stick match

3 booms and 6 different sticks allow you to choose the best match for each job. Computer aided design and stress analysis of all front-end structures give the best combination of durability and weight control. **pg. 9**

---

### The cab: a new reference

Pilot operated joysticks control front-end and swing functions. The tiltable steering column and the pedal controls offer optimal comfort. The control panel informs the operator of the machine status at all times. Large windows offer good visibility while roading and working in tight quarters. The fully adjustable seat offers lumbar support. Heater, defroster, and fan keep positive filtered air (warm, fresh, or cool if equipped with the air conditioner option) flowing through the cab at the flip of a switch. **pg. 4-5**

---

### Cat '5 Star Customer Service'

Turns your investment into profit, from purchase to resale through:

- Equipment Management Services for optimum profit
- Maintenance Services for equipment protection
- Predictive Services for optimum availability
- Reconditioning Services for lower repair cost
- Your Caterpillar dealer for satisfaction and peace of mind

**pg. 23**



## Outstanding operator comfort

*Plenty of room, all-around visibility, and ergonomic layout for convenient operation.*

### Easy access

Conveniently located grab irons and large steps mounted on the undercarriage allow easy access to the cab.

### A quiet cab

The cab is resiliently mounted. Sound suppression panels considerably reduce outside noise levels.

### A comfortable seat

The suspension seat adjusts to the operator's weight and offers excellent lumbar support. There are height-adjustable armrests and numerous seat adjustments.

### Outstanding visibility

Wide windows help ensure excellent visibility in all directions. This is especially critical when roading the machine or when working on public roadways. A parallelogram windshield wiper clears the front window efficiently in rainy weather. Rear visibility is excellent thanks to the small engine cover. The standard skylight provides upward visibility.

### Excellent ventilation

Strategically located vents circulate forced air, heat, or defrost air for maximum comfort. The two-piece front window has multiple positions. In rainy weather, the lower front window can be tilted inwards to provide fresh air and the skylight can be opened for additional ventilation. For work in hot weather conditions, an optional air conditioner is available.

### Practical controls

- The control panel switches are conveniently located.
- Warning lights are clearly visible on the upper portion of the control panel.
- Joysticks require low effort and a short stroke for maximum control and efficiency.
- Ample space is reserved for the additional switches and pedals used to activate optional equipment.





# Maestro Mobile electronic system

An electronic system matching the state-of-the-art hydraulic system designed specifically for wheel excavator applications.

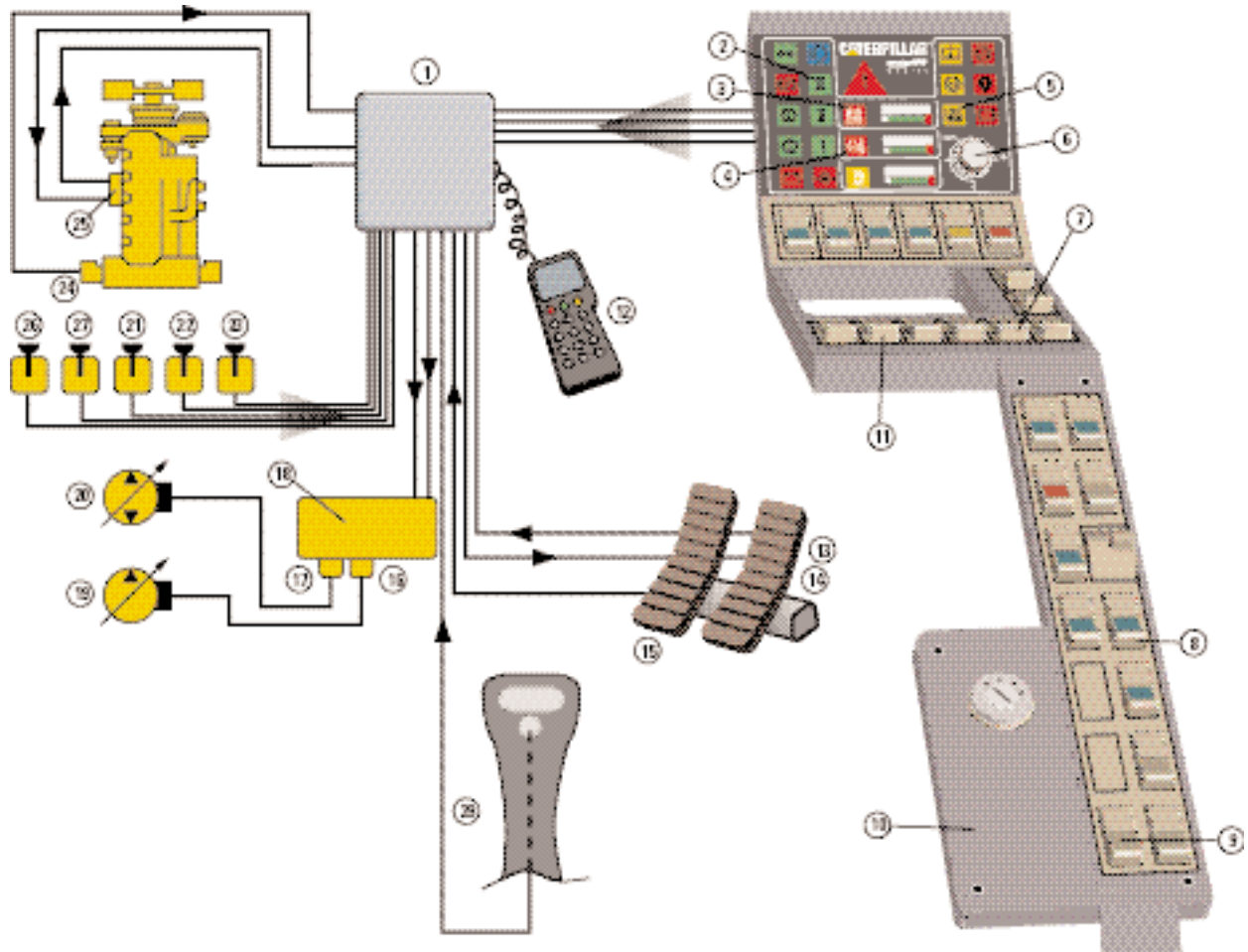

- |  |   |   |
|--|---|---|
| <b>1</b> Microprocessor                        | <b>10</b> RH console  | <b>19</b> Main pump                             |
| <b>2</b> Power mode III indicator              | <b>11</b> Power mode switch (I/II)  | <b>20</b> Swing pump                            |
| <b>3</b> Hydraulic oil temperature – high      | <b>12</b> Diagnostic tool or laptop-PC running <i>Cat Electronic Technician (ET)</i> software | <b>21</b> Brake light switch                    |
| <b>4</b> Engine coolant temperature – high     | <b>13</b> Travel pedal switch   | <b>22</b> Pressure switch – AEC Main pump       |
| <b>5</b> Hydraulic oil temperature – low       | <b>14</b> Travel pedal magnet   | <b>23</b> Pressure switch – AEC Swing pump      |
| <b>6</b> Engine speed dial                     | <b>15</b> Brake light pressure switch   | <b>24</b> Engine speed pick-up                  |
| <b>7</b> Travel lock switch                    | <b>16</b> Main pump PRV   | <b>25</b> Governor actuator and feedback sensor |
| <b>8</b> Automatic engine control (AEC) switch | <b>17</b> Swing pump PRV  | <b>26</b> Pressure switch – AEC stick cylinder  |
| <b>9</b> Back-up switch                        | <b>18</b> Pilot manifold  | <b>27</b> Pressure switch – AEC boom cylinder   |
|  |   | <b>28</b> One touch idle down button            |

### **State-of-the-art hydraulic system**

Closed center, variable flow, load-sensing plus. A variable displacement piston pump powers the boom, stick, bucket, outriggers/dozer, and travel circuit.

A gear pump powers the steering system, the brake system, and the pilot control system, and, if equipped, the medium pressure function.

### **A dedicated swing pump**

A separate dedicated variable displacement piston pump and fixed displacement piston motor power the swing mechanism. This closed hydraulic circuit helps to provide maximum swing performance and control at all times.

### **An efficient and expandable hydraulic system**

Up to four optional hydraulic valves can be added to the main valve stack for additional hydraulic functions.

A medium pressure auxiliary hydraulic circuit is also available. These features offer almost unlimited auxiliary hydraulic capability.

### **Maestro Mobile Control Panel**

The right side console, shown on page 6, contains switches for the power mode selector, automatic engine control, lights, windshield wiper and washer, and travel speed selector.

### **Integrated electronic system**

A microprocessor monitors and controls all M312 parameters and functions. The microprocessor was designed specifically for a wheel excavator to maximize the efficiency of the engine and the hydraulic system.

This Electronic Control System monitors and controls the following functions:

**Engine Speed Control Via Potentiometer** – The diesel final control element at the diesel engine is controlled via a potentiometer in the instrument panel. A button on the right joystick immediately sets the idle down manually.

**Three power mode settings** – There are three power mode settings. The operator can choose the best power setting for both engine and hydraulics, without any loss of hydraulic force.

**Mode III** – Works only during travel and is automatically engaged. It provides maximum speed and drawbar pull.

**Mode II** – The standard mode, used for normal truck loading, trenching, and hydraulic hammer use.

**Mode I** – The economy mode, used for lifting, pipe setting, bank forming, grading, slope finishing, and close quarter and precise work. This mode helps ensure minimum fuel consumption.

**Automatic Engine Speed Control** – When activated, this device reduces engine speed to a minimum during periods of inactivity. This reduces noise and saves fuel.

**Electronic Underspeed Control** – Constant electronic monitoring assures that the pump output is always matched to diesel engine power. As a result, a nearly constant diesel engine speed can be maintained.

**Protective Measures** – Maximum power is reduced when engine temperature is too high or the hydraulic temperature is either too low or too high.

**Diagnostic System** – System parameters and failure identification codes can be read by means of a diagnostic tool.

**Top Speed Adjustment (optional)** – This holds the travel pedal in the maximum position to reduce strain on the operator. The pedal is released by activating the brake.

## Cat 3054 TA engine

*An emission controlled engine offering the latest environmental benefits.*

- Conservative 85 kW rating, high power to displacement ratio of 21.2 kW/liter and low rpm operation help ensure long life and exceptional reliability.
- The 3054 TA engine meets the European Union 97/68/EC Non-Road Mobile Machinery Engine Emission Directive and the current US EPA Non-Road Regulation.
- Four-stroke-cycle design uses long power strokes for more complete fuel combustion and efficiency. Accurate fuel metering results in low fuel consumption.
- Long-life design includes large bearing surfaces, alloy steel valves, lightweight cam roller followers, and easily replaceable crankshaft seals.
- The engine is designed for high torque rise at medium rpm. This is suited for excavator applications.
- The engine is longitudinally mounted on the right to make it easier to serve the oil filter, oil filler, oil drain valve, fuel filter, V-belt tightener, and dipstick which are all accessible from ground level.
- Low engine noise emissions make the M312 a real friendly machine which helps protect the environment:  
 $L_{pA} - 72 \text{ dB(A)}$ ;  
 $L_{wA} - 99 \text{ dB(A)}$   
Dynamically measured according to ISO6396 or 95/27/EC.

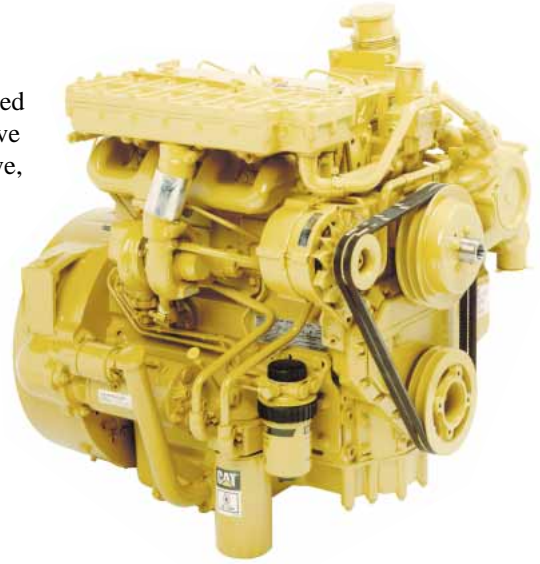

## Undercarriage, outriggers, dozer blade, axles

*Undercarriage and axles match: providing maximum flexibility and mobility.*

**Undercarriage** – A strong and long-life welded frame structure built with large sections and thinner plates for excellent rigidity. The frame has been Finite Element Method analyzed. Both the dozer blade and the outriggers feature a pin-on design.

**Axles** – Heavy duty axles. The front axle offers one of the best axle oscillation and steering in the industry for optimized flexibility and mobility.

**Outriggers** – Recommended for maximum operation stability when digging and lifting. They can be controlled individually to level the machine on slopes. Pin-on design, including standard outriggers cylinder guards. Can be mounted on the front and/or on the rear.

**Dozer Blade** – A useful addition for leveling and backfilling or clean-up work, also used to improve machine stability when digging or lifting. Pin-on design, including standard dozer blade cylinders guard. This can be mounted on the front and/or on the rear.

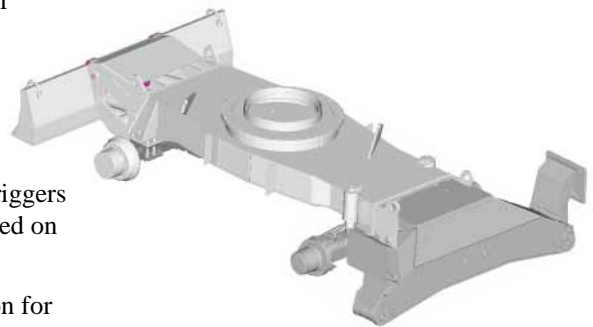



## Booms and sticks

Choose the boom/stick combination best matching your needs. Contact your Cat dealer for more information.

### 1 One-piece Boom 4.8 meters – For all standard applications.

It is built with large sections and thinner plates for maximum weight reduction and durability and has been Finite Element Method analyzed. Recommended for hammer applications.

### 2 Hydraulically Adjustable Boom (VA) max. 5.05 meters –

For improved visibility and machine roading balance. Indicated when working in tight quarters. It is built with large sections and thinner plates for maximum weight reduction and durability and has been Finite Element Method analyzed.

### 3 VA Offset boom 5.05 meters – In this configuration, the VA boom can be adjusted horizontally, as well. Use this boom to dig along walls, underneath pipes, or grade while roading. With the offset boom, you can use a 2.0 m or a 2.3 m stick. The offset distance to each side is 2.4 m. Due to the offset boom's durability, it is suitable for hammer applications.

**Sticks** – 6 stick lengths are available for maximum flexibility. They are built with large sections and thinner plates for maximum weight reduction and durability. They have been Finite Element Method analyzed.

- Short stick: 1.6 m
- Medium stick: 2.0 m
- Medium / long stick: 2.3 m
- Long stick: 2.6 m
- Extra long stick: 3.0 m
- Material handling stick: 2.8 m.

**Industrial arrangement** – For industrial or agricultural applications choose the best matching boom and the 2.8 m industrial droop nose stick. With this stick, a free swinging work tool can be used.

**Bucket linkage** – Two bucket linkages are offered. One with diverter valve, the other without.

**4 Finite Element Analysis** – With FEA, a most stable and reliable base frame and upper frame structure could be designed. For maximum strength and best range, also all linkage parts (boom, sticks) have been analyzed to help optimize the balance of weight reduction versus fatigue strength. This also includes the offset boom.

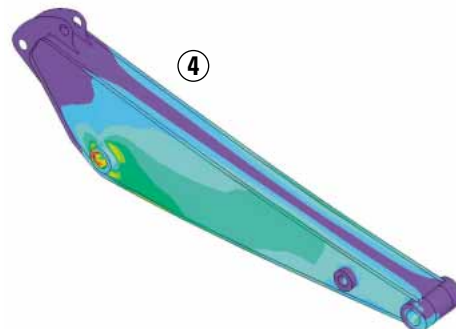

## Hydraulics

*The M312 hydraulic system provides more performance and efficiency to your jobs.*

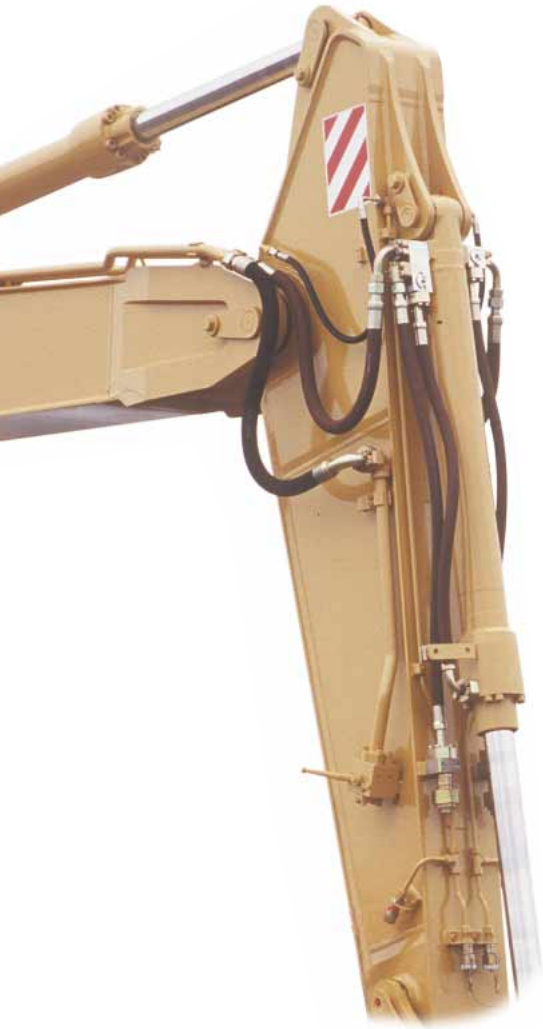

**Efficient and expandable hydraulic system** – The flow distances between hydraulic components are minimized. This helps provide maximum hydraulic efficiency. The load independent flow distribution together with the separate swing pump helps ensure maximum power at all times.

- Load independent flow distribution and control system with pressure cut-off. The pump flow is independently and proportionally distributed to the flow users. This is a flow-on-demand hydraulic system offering multi-function capability.
- Optional hydraulic valves can be flanged to the main valve stack for maximum hydraulic flexibility.

**Caterpillar XT hoses and couplings** – meet the critical flexibility and strength demands of wheel excavator applications. O-ring face seal couplings provide positive sealing for reliable and leak-free connections.

**Hammer Lines (optional)** – Factory installed hammer hydraulic lines are available. These lines allow single acting function for dedicated proportional hammer foot control for maximum comfort and precision. Optimized hose routing provides excellent protection and durability.

**High Pressure Hydraulic Lines (optional)** – Factory installed high pressure lines are available. They are designed to function with 2-way hydro-mechanical attachments such as shears and crushers at maximum working pressure and flow. Optimized hose routing provides excellent protection and durability.

**Medium Pressure Hydraulic Lines (optional)** – Factory installed medium pressure lines are available. They are designed to function with double-acting rotating devices such as the ditch cleaning bucket tilt and the clamshell rotation. Optimized hose routing provides excellent protection and durability.

## Serviceability

*Simplified service and maintenance features save you time and money.*

**Fast, easy maintenance** means improved uptime and better value.

**Ground level service points** for fuel-water separator, engine oil filter, battery, radiator fluid level, window washer fluid level, fuel filter, engine oil gauge, hydraulic oil level, air cleaner and pilot system filter.

**Filters and filter locations** make maintenance easier.

- Air cleaner has double layered filter core and built-in air precleaner for better filtration. No tools required to change.
- Operator is alerted by warning light in cab to need for filter change.
- Engine oil filter, fuel filter and fuel-water separator are positioned for easier access.
- Pilot hydraulic system filter keeps contaminants away from the pilot system.

**Water separator removes water from fuel** even when under pressure and is located in the engine compartment.

**Remote greasing block** on the upper frame with two grease points for the swing bearing and one for the front end attachment to deliver grease to hard to reach locations.

## Buckets and work tools

A wide variety of buckets and work tools help optimize machine performance. Purpose designed and built to Caterpillar's high durability standards.

**Work Tools** – A variety of work tools are available from your Cat dealer for the M312 wheel excavator. These include quick couplers, different kinds of grapples, and demolition and sorting tools such as shears, pulverizers, or hydraulic hammers.

### Tip selection

The following tips are available for the buckets for the M312:

- Long Tips
- Short Tips
- Abrasive Tips
- Penetration Tips
- Sharp Corner Tips
- Wide Tips

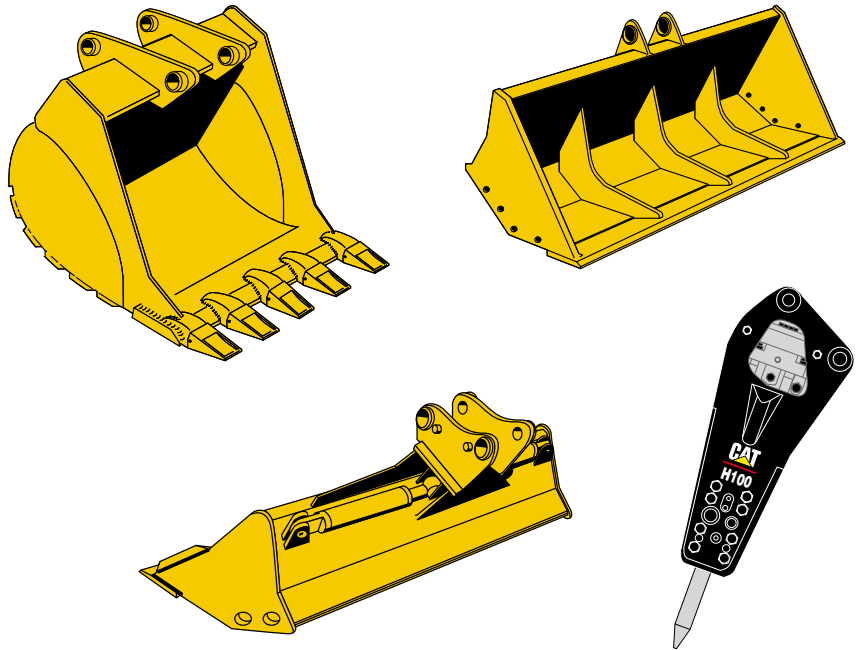

## Bucket specifications

		General Purpose											
<b>A</b>	Bite width	mm	450	600	700	*750	*850	900	1000	*1000	1100	1200	*1200
<b>B</b>	Tip radius	mm	1240	1240	1240	1318	1318	1240	1240	1318	1240	1240	1318
	SAE rated capacity	m <sup>3</sup>	0.24	0.33	0.40	0.47	0.56	0.54	0.61	0.68	0.68	0.75	0.86
	Weight with tips	kg	271	304	340	430	473	365	410	520	438	458	592
	Number of teeth		3	3	4	3	4	5	5	4	6	6	5
		Extreme Service					Ditch Cleaning						
<b>A</b>	Bite width	mm	1100	1200				1800	1800	2000	2000		
<b>B</b>	Tip radius	mm	1240	1240				732	1082	732	1008		
	SAE rated capacity	m <sup>3</sup>	0.68	0.75				0.48	0.48	0.54	0.40		
	Weight with tips	kg	472	493				385	364	416	365		
	Number of teeth		6	6									
								Rigid	Tiltable	Rigid	Tiltable		

All buckets include weld-on tooth adapters.

All buckets are available with or without adjuster group:

All weights are with tips.

\* J300 tips required, buckets without \* require J250 tips.

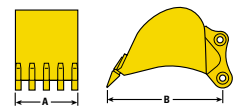

**Buckets (optional)** – A complete range of Cat specifically designed general purpose buckets are available for maximum flexibility.

All are available either with or without adjuster groups.

A range of tiltable and rigid ditch cleaning buckets are also available.

Tips can be chosen from the J250 / J300 G.E.T offering.

## Engine

Caterpillar four-stroke-cycle, four cylinder 3054 TA turbocharged aftercooled diesel engine.

<b>Ratings at 2000 rpm</b>	kW	hp
Gross power	88	117
Net power	85	114

The following ratings apply at 2000 rpm when tested under the conditions for the specified standard:

Net power	kW	hp
ISO 9249	85	114
EEC 80/1269	85	114

### Dimensions

Bore	100 mm
Stroke	127 mm
Displacement	4.0 liters
Maximum torque	450 Nm
Torque rise	6.7% at 1600 rpm

- An emission controlled engine. Meets the 97/68/EC Non-Road Mobile Machinery Engine Emission Directive and the current US EPA Non-Road Regulation.
- Longitudinal mounting on the right for easy ground access for service/maintenance of: oil filter, oil filler, oil drain valve, fuel filter, V-belt tightener, dipstick.
- An electric 24-volt starting system with a 55 amp alternator and two, 12-volt, 100 amp hour Caterpillar Maintenance-Free batteries.
- An air cleaner, dry type with radial seal primary and secondary element. Easy and rapid to service and replace.
- Maximum altitude at full power: 2300 meters.

## Environmental features

The M312 offers a list of features to help protect the environment.

- Low fuel consumption. Compared to power and performance, the M312 has a low level of fuel consumption.
- Biodegradable hydraulic oil. On the M312, you can use a biodegradable hydraulic oil to help protect the environment and meet governmental requirements in certain countries.
- The M312 features extremely low operator and spectator sound levels.
- The emission controlled engine complies with the 97/68/EC Non-Road-Machinery Engine Emission Directive.

<b>Emission values</b>	g/kWh
Hydrocarbons (HC)	below 1.3
Carbon Monoxide (CO)	below 5.0
Nitrogen Oxide (NO <sub>x</sub> )	below 9.2

### Noise levels

L<sub>pA</sub> – 72 dB(A); L<sub>WA</sub> – 99 dB(A)

Dynamically measured according to ISO6396 or 95/27/EC.

## Brakes

Maintenance free wet-disc service brakes on the front and rear axles are standard.

- A fully hydraulic service brake system. Braking system is supplied with hydraulic oil from a separate gear pump mounted on the engine.
- A dual-circuit braking system with independent front and rear axle service brake circuits, for increased safety.
- Two separate pre-charged hydraulic accumulators, one per circuit, for increased safety.
- A disc brake parking brake located in the transmission housing. Spring applied and hydraulically released.

## Axles and final drives

Planetary axles with planetary gear reduction final drives located in the axle hubs.

- All-wheel drive.
- High quality graphite iron axle housings for maximum strength and durability.
- Front steering axle oscillates 9° for improved stability and manoeuvrability in rough terrain.
- Front axle can be locked from operator station in any position of oscillation for improved working stability.

Ground clearance (with standard tires)	375 mm
Axle static load capacity	26 000 kg

## Hydraulic system

### Main Hydraulic System

Maximum flow	190 l/min
Maximum pressure	
Implements	330 bar
Travel	330 bar
Optional heavy lift circuit	370 bar

### Pilot System

Maximum flow	15 l/min
Maximum pressure	32 bar

## Maestro Mobile electronic control system

The microcontroller monitors and controls the interference between the engine and the hydraulics.

- Automatically passes into power mode III to help maximize power when travel is activated.
- Balances pump output and engine power in power modes I and II to help maximize efficiency.
- Automatic engine control (AEC), provides automatic engine low idle for noise and fuel reduction and operator comfort.
- 3 power modes: travel mode, standard mode, economy mode.
- The electrical back-up system for the microprocessor is standard. The switch is in the cab.
- The central diagnostic function records system parameters or faults. It can be read by dealer technicians with portable diagnostic tools for fast analysis and troubleshooting.

## Steering

Fully hydraulic, powered by a separate gear pump mounted on the engine.

- Maintenance-free steering system.
- Synchronized steering cylinder integrated in the steering axle housing to help maximize protection.
- Steering angle of 35° for reduced turning circle and mobility.
- Optional battery-powered supplemental steering system.

Outer turning circle diameter	12.4 m
Vehicle clearance turning circle	
with one-piece boom	16.4 m
with VA boom	13.55 m

## Transmission

2-gear power-shift transmission. Permanent all wheel drive.

- Forward, reverse travel and speed are controlled by a single foot pedal on the right side of the steering column.
- The transmission is protected by a downshift governor to help prevent high-to-low shift until pre-set slower ground speed is reached.
- The overspeed valve limits downhill travel speed in forward and reverse gears.
- An optional two-piece drive shaft with an intermediate bearing to help maximize ground clearance is available.
- The transmission is flanged to the differential housing of the rear axle for maximum protection by axle and base frame, and for better ground clearance.
- Standard creeper speed.
- Optional travel speed lock for operator comfort. This locks the travel pedal for long distance travelling.

### Speeds

1st gear, forward/reverse	9 km/h
2nd gear, forward	20/25/30/34 km/h
2nd gear, reverse	20 km/h
Creeper speed (first gear)	3-4 km/h
Creeper speed (second gear)	11-16 km/h
Drawbar pull	70 kN
Gradeability	61%

## Tires

Dual pneumatic 10.00-20 tires are standard.

- Optional tires:
- 10.00-20 (dual solid rubber),
  - 18R 19.5 XF (super single).

## Service refill capacities

	Liters
Fuel Tank	230
Cooling	35
Lubrication	
Engine	9
Rear axle housing, differential	11
Front steering axle, differential	7
Final drives, front (each)	2
Final drives, rear (each)	2
Powershift transmission	3
Hydraulic system (including tank)	180
Hydraulic tank	95

## Controls

Two pilot-operated revolver type hand levers actuate boom, stick, bucket and swing (SAE pattern).

### Right lever

- Move forwards and backwards to lower and raise boom,
- Move left and right to control bucket curl and dump,
- Press button on top of control to activate the optional auxiliary circuit in one direction.

### Left lever

- Move forwards and backwards to move stick out and in,
- Move left and right to control the direction of swing,
- Press button on top of control to activate the optional auxiliary circuit in one direction.
- Press single button on top of control to activate the swing brake.

### Pedals to the right of the steering column

- Service brake pedal is immediately to the right of the steering column. Fully depressed brake pedal automatically locks oscillating axle
- Forward and reverse rocker travel pedal is located to the right of the service brake pedal.

### Pedals to the left of the steering column

- Optional VA boom rocker control pedal is immediately to the left of the steering column,
- Optional hammer or auxiliary hydraulic high pressure function control pedal is located to the left of the VA boom rocker control pedal.

**Left side console** lifts for operator entry and exit. Raising the side console isolates all hydraulic functions except steering. This console must be raised to start the engine.

## Swing mechanism

Dedicated variable displacement axial-piston pump and fixed-displacement axial-piston motor powers the swing mechanism.

- Closed hydraulic circuit, flow and torque controlled with pressure cut-off for maximum swing performance and control. Swing output is power mode influenced.
- Double-reduction, planetary swing drive.
- Splash lubricated.
- Maintenance free gear mechanism.
- Adjustable constant brake torque while coasting when the swing control is released.
- Maximum holding torque at operating pressure in a standstill position.
- Automatic swing brake is activated after 3.5 seconds of no swing operation. Additional emergency swing brake button on joystick.
- Standard manual swing lock pin actuated from the cab for machine transportation.

### Swing system

Maximum flow	80 l/min
Maximum pressure	355 bar
Swing torque	31.6 kNm
Max. swing speed	11 rpm

## Weights

Average operating weights include general purpose bucket, 100% fuel and operator. An optional additional counterweight of 400 kg is available.

	Offset VA boom 1 set of outriggers/dozer kg	One-piece boom 1 set of outriggers/dozer kg	VA boom dozer only kg
Stick			
1600 mm	–	13 570	13 230
2000 mm	14 720	13 570	13 220
2300 mm	14 750	13 600	13 250
2600 mm	–	13 650	13 300
3000 mm	–	13 670	13 320

For the following equipment change the above weights:

Offset VA boom	–	+950	+550
One-piece boom	–950	–	–400
VA boom	–550	–400	–
Dozer only	–800	–800	–
1 set of outriggers only	+650	–650	+150
2 sets of outriggers	+150	+150	+950
1 set of outriggers/dozer	–	–	+800

### Undercarriage with dozer only

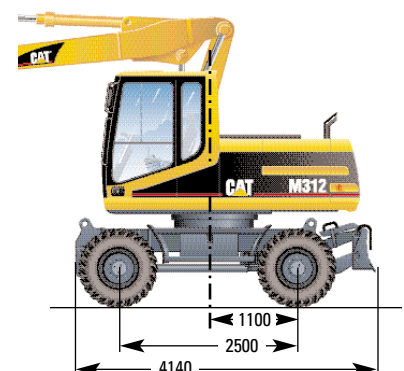

# Dimensions

All dimensions are approximate – measured in mm

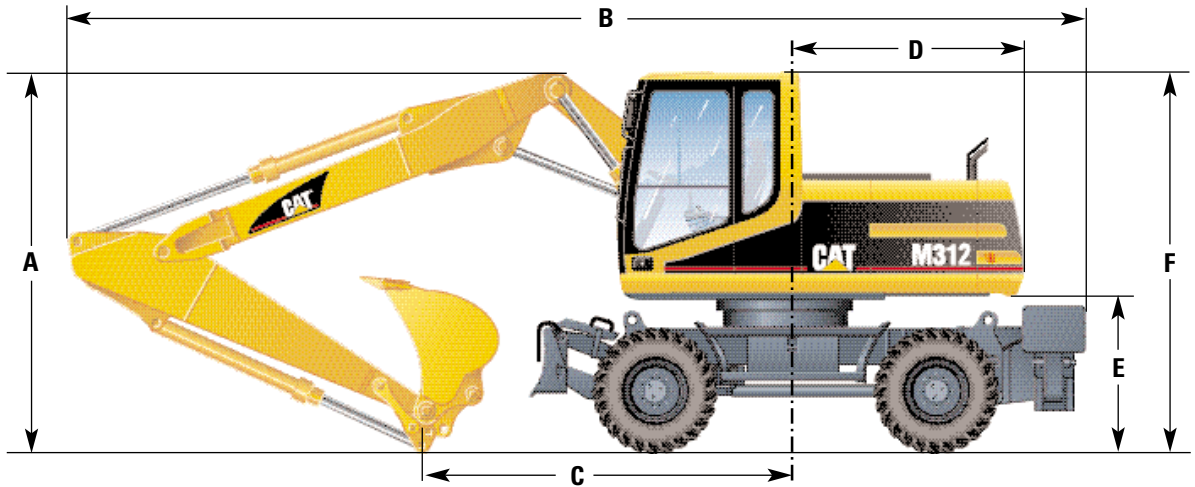

	One-piece boom	VA boom	Offset boom
<b>A</b> Shipping height			
1600 mm stick	Cab height	Cab height	–
2000 mm stick	Cab height	Cab height	2980
2300 mm stick	Cab height	3090	Cab height
2600 mm stick	Cab height	3180	–
3000 mm stick	*Cab height	3220	–
<b>B</b> Shipping length			
1600 mm stick	8450	8690	–
2000 mm stick	8090	8350	8070
2300 mm stick	**8620	8350	**8600
2600 mm stick	**8630	8340	–
3000 mm stick	*8090	8330	–
<b>C</b> Support Point			
1600 mm stick	4060	4460	–
2000 mm stick	3330	3780	3710
2300 mm stick	3140	3620	3550
2600 mm stick	2970	3480	–
3000 mm stick	2460	3020	–

<b>D</b> Tail swing radius	1990
<b>E</b> Counterweight clearance	1262
<b>F</b> Cab height	3070

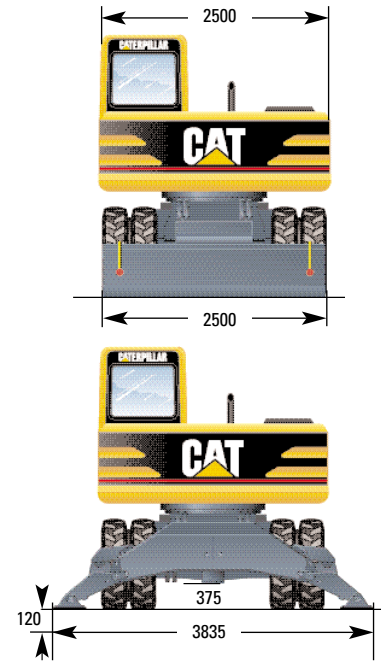

\* Bucket removed  
\*\* Linkage over dozer

**Undercarriage with 2 sets of outriggers**

**Undercarriage with 1 set of outriggers and dozer**

**Roading position with 2.6 m stick**

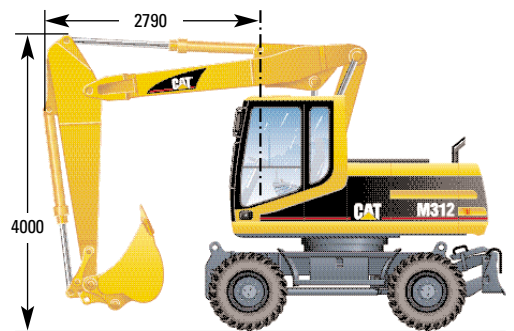
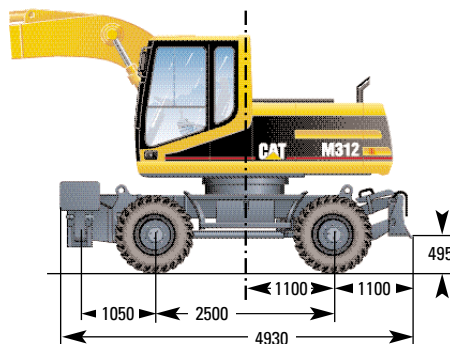
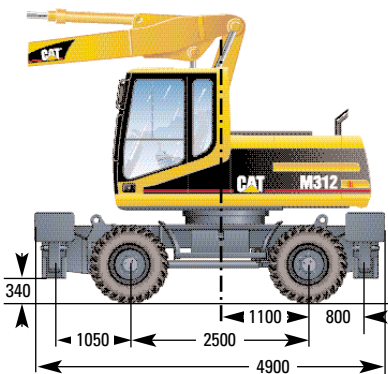

# Working ranges

With one-piece boom

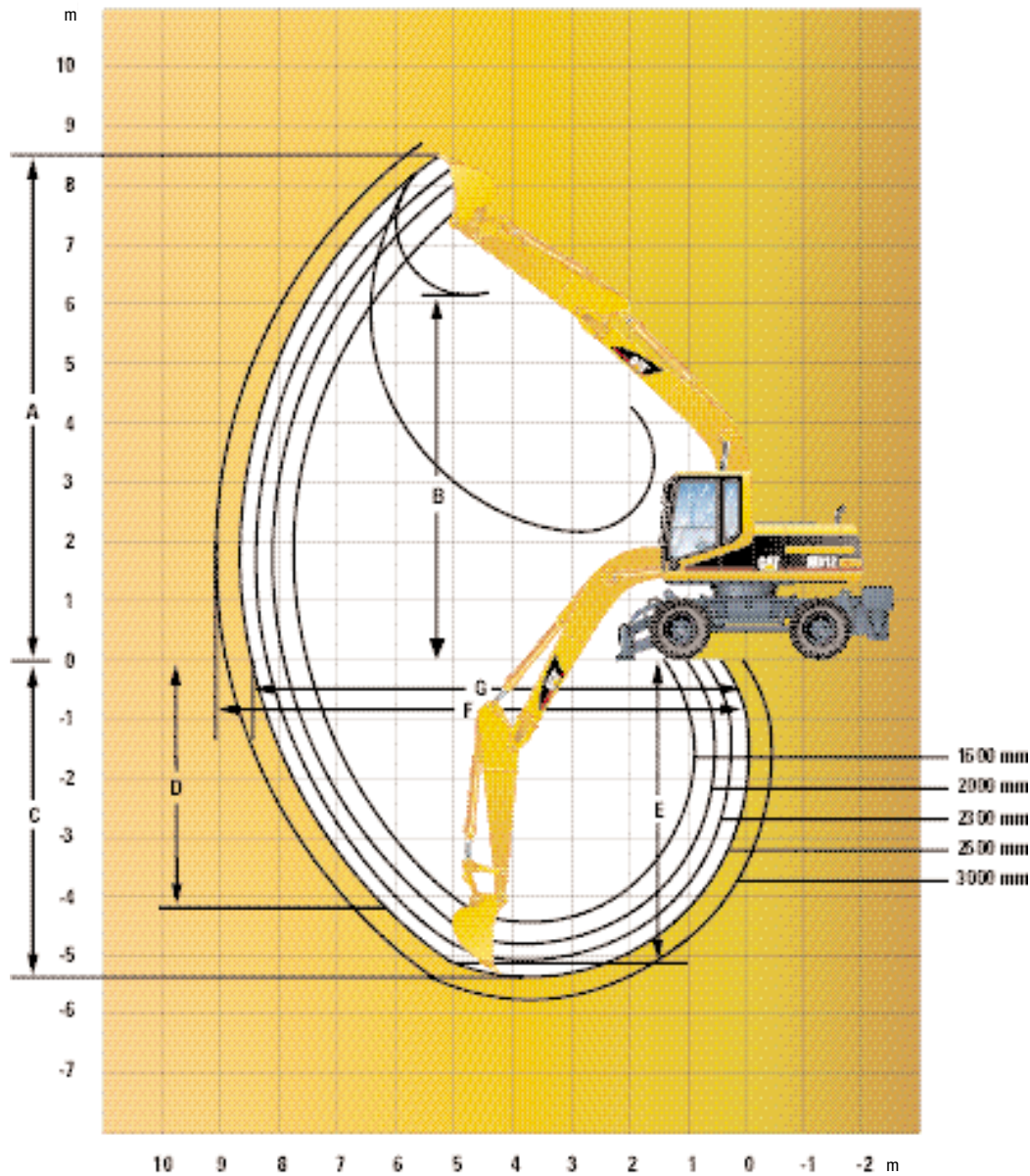

Stick	1600 mm	2000 mm	2300 mm	2600 mm	3000 mm
<b>Bucket</b>	<b>0.68 m<sup>3</sup></b>	<b>0.68 m<sup>3</sup></b>	<b>0.61 m<sup>3</sup></b>	<b>0.61 m<sup>3</sup></b>	<b>0.54 m<sup>3</sup></b>
<b>A</b> Maximum cutting height	7880 mm	8210 mm	8380 mm	8550 mm	8520 mm
<b>B</b> Maximum loading height	5640 mm	5860 mm	6030 mm	6190 mm	6200 mm
<b>C</b> Maximum digging depth	4420 mm	4820 mm	5120 mm	5420 mm	5820 mm
<b>D</b> Maximum vertical wall digging depth	2390 mm	3750 mm	4030 mm	4300 mm	4390 mm
<b>E</b> Maximum depth of cut, for 2500 mm level bottom	4110 mm	4570 mm	4890 mm	5210 mm	5630 mm
<b>F</b> Maximum reach	7830 mm	8200 mm	8490 mm	8770 mm	9080 mm
<b>G</b> Maximum reach at ground level	7620 mm	8010 mm	8300 mm	8590 mm	8900 mm

Digging forces (SAE):

Stick	72 kN	57 kN	52 kN	48 kN	44 kN
Bucket	88 kN	80 kN	80 kN	80 kN	80 kN



# Working ranges

With hydraulically adjustable (VA) boom and Offset VA boom\*.

\* The working ranges of the Offset VA boom equal the ones of the VA boom.

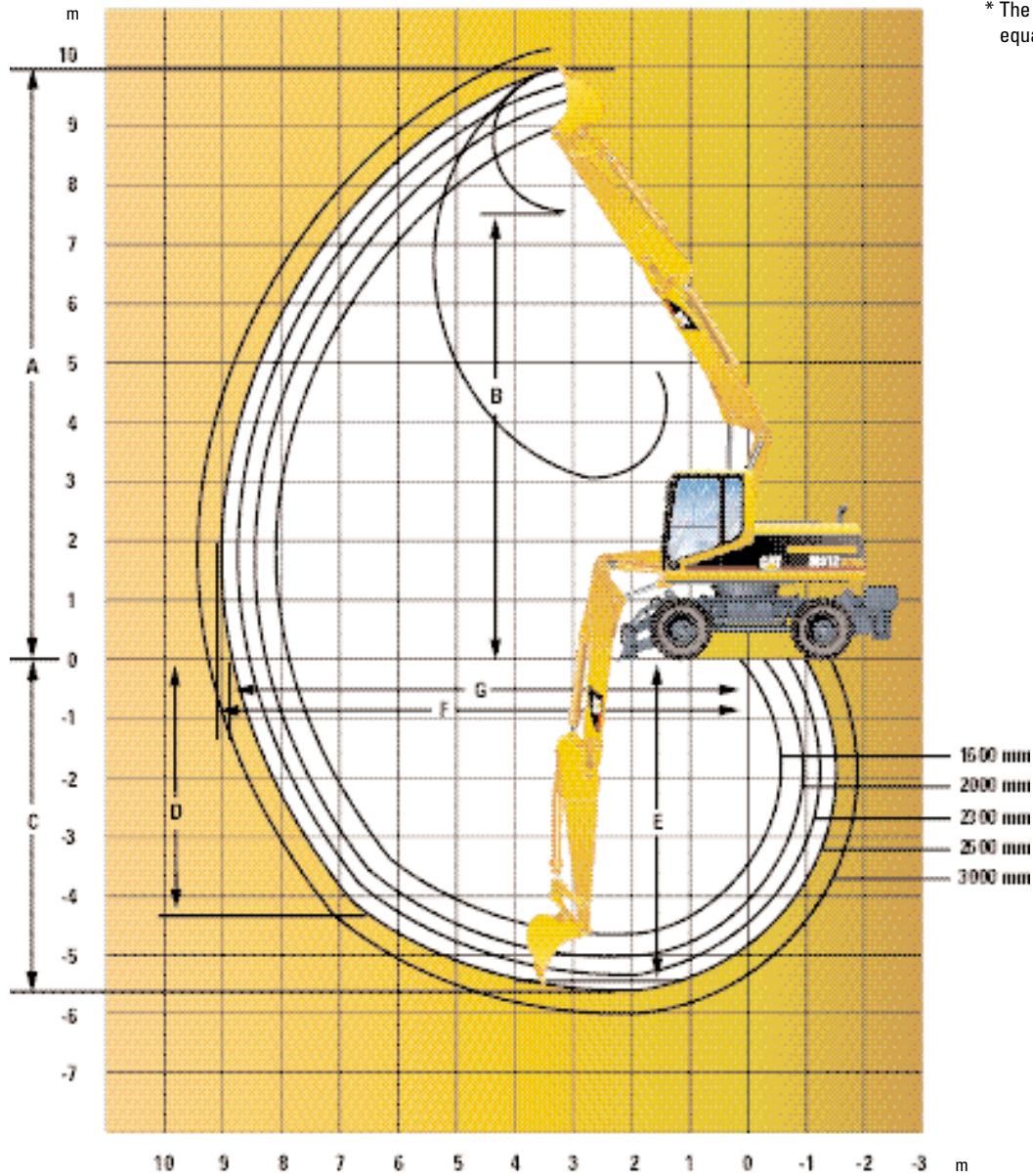

Stick	1600 mm	2000 mm	2300 mm	2600 mm	3000 mm
<b>Bucket</b>	<b>0.68 m<sup>3</sup></b>	<b>0.61 m<sup>3</sup></b>	<b>0.54 m<sup>3</sup></b>	<b>0.54 m<sup>3</sup></b>	<b>0.40 m<sup>3</sup></b>
<b>A</b> Maximum cutting height	9130 mm	9490 mm	9730 mm	9970 mm	10130 mm
<b>B</b> Maximum loading height	6760 mm	7050 mm	7290 mm	7540 mm	7700 mm
<b>C</b> Maximum digging depth	4620 mm	5020 mm	5320 mm	5620 mm	6000 mm
<b>D</b> Maximum vertical wall digging depth	2850 mm	3840 mm	4110 mm	4390 mm	4620 mm
<b>E</b> Maximum depth of cut, for 2500 mm level bottom	4490 mm	4900 mm	5210 mm	5510 mm	5900 mm
<b>F</b> Maximum reach	8110 mm	8490 mm	8780 mm	9070 mm	9390 mm
<b>G</b> Maximum reach at ground level	7900 mm	8300 mm	8590 mm	8890 mm	9220 mm

Digging forces (SAE):

Stick	72 kN	57 kN	52 kN	48 kN	44 kN
Bucket	88 kN	80 kN	80 kN	80 kN	80 kN

# Lift capacities\*\*

with one-piece boom – 4.80 m

## Stick Bucket

1.6 m 0.68 m<sup>3</sup>

Stick	Undercarriage configuration	3.0 m			4.5 m			6.0 m			7.5 m			8.0 m			m
		Upright	45°	90°	Upright	45°	90°	Upright	45°	90°	Upright	45°	90°	Upright	45°	90°	
6.0m	Rear dozer up Rear dozer down Rear stab down 2 sets stab down Dozer and stabdown				*3.9 *3.9 *3.9 *3.9	2.9 3.4 *3.9 *3.9											
4.5m	Rear dozer up Rear dozer down Rear stab down 2 sets stab down Dozer and stab down				*4.4 *4.4 *4.4 *4.4	2.9 3.3 *4.0 *4.4	2.9 *3.8 *3.8	1.7 2.0 2.4 *3.7 3.1									
3.0m	Rear dozer up Rear dozer down Rear stab down 2 sets stab down Dozer and stab down				4.6 *5.3 *5.3 *5.3 *5.3	2.6 3.1 3.8 *5.3 4.8	2.9 *4.1 *4.1	1.7 1.9 1.7 *3.7 *3.0						2.1 *2.5 *2.5		1.2 1.4 1.7 *2.5 2.2	7.36
1.5m	Rear dozer up Rear dozer down Rear stab down 2 sets stab down Dozer and stab down				4.3 *6.1 *6.1 *6.1 *6.1	2.4 2.9 3.6 5.6 4.5	2.8 4.5 4.0 *4.5	1.6 1.8 2.3 3.6 2.9						1.9 *2.5 *2.5		1.1 1.3 1.6 2.5 2.0	7.64
Ground	Rear dozer up Rear dozer down Rear stab down 2 sets stab down Dozer and stab down				4.2 *6.3 *6.3 *6.3 *6.3	2.3 2.8 3.5 5.6 4.5	2.8 *4.5 4.0 *4.5	1.6 1.8 2.3 3.6 3.9						1.9 *2.7 *2.7		1.1 1.3 1.6 2.5 2.0	7.83
-1.5m	Rear dozer up Rear dozer down Rear stab down 2 sets stab down Dozer and stab down	*7.2 *7.2 *7.2 *7.2	4.4 5.3 6.9 *7.2 *7.2	4.2 *5.9 *5.9 *5.9 *5.9	2.4 2.8 3.5 5.6 4.5								2.1 *3.1 *3.1		1.2 1.4 1.8 2.8 2.3	7.08	
-3.0m	Rear dozer up Rear dozer down Rear stab down 2 sets stab down Dozer and stab down	*6.1 *6.1 *6.1 *6.1 *6.1	4.6 5.5 *6.1 *6.1 *6.1	*4.2 *4.2 *4.2 *4.2 *4.2	2.5 2.9 3.6 *4.2 *4.2												

## Stick Bucket

2.0 m 0.68 m<sup>3</sup>

Stick	Undercarriage configuration	3.0 m			4.5 m			6.0 m			7.5 m			8.0 m			m
		Upright	45°	90°	Upright	45°	90°	Upright	45°	90°	Upright	45°	90°	Upright	45°	90°	
	Rear dozer up Rear dozer down Rear stab down 2 sets stab down Dozer and stab down																
4.5m	Rear dozer up Rear dozer down Rear stab down 2 sets stab down Dozer and stab down				*4.1 *4.1 *4.1 *4.1 *4.1	2.9 3.4 *4.1 *4.1 *4.1	3.0 *3.6 *3.6 *3.6 *3.6	1.8 2.0 2.5 *3.6 3.1									
3.0m	Rear dozer up Rear dozer down Rear stab down 2 sets stab down Dozer and stab down				4.7 *5.1 *5.1 *5.1 *5.1	2.7 3.2 3.9 *5.1 4.9	2.9 *4.0 *4.0	1.7 2.0 2.4 3.7 3.1						*1.6 *1.6 *1.6 *1.6		1.1 1.3 1.6 *1.6 *1.6	7.75
1.5m	Rear dozer up Rear dozer down Rear stab down 2 sets stab down Dozer and stab down				4.4 *6.0 *6.0 *6.0 *6.0	2.5 2.9 3.7 5.8 4.7	2.8 *4.4 4.1 *4.4 *4.4	1.6 1.9 2.3 *3.6 3.0						*1.6 *1.6 *1.6 *1.6		1.0 1.2 1.5 *1.6 *1.6	8.01
Ground	Rear dozer up Rear dozer down Rear stab down 2 sets stab down Dozer and stab down				4.3 *6.4 *6.4 *6.4 *6.4	2.4 2.8 3.5 5.6 4.5	2.8 4.6 4.0 *4.6 *4.6	1.6 1.8 2.3 3.6 2.9						*1.7 *1.7 *1.7 *1.7		1.0 1.2 1.5 *1.6 *1.6	7.93
-1.5m	Rear dozer up Rear dozer down Rear stab down 2 sets stab down Dozer and stab down	*6.6 *6.6 *6.6 *6.6 *6.6	4.4 5.3 *6.6 *6.6 *6.6	4.3 *6.1 *6.1 *6.1 *6.1	2.4 2.8 3.5 5.6 4.5	2.7 *4.3 4.0 *4.3 *4.3	1.5 1.8 2.3 3.5 2.9						2.0 *2.0 *2.0 *2.0		1.1 1.3 1.6 *2.0 *2.0	7.49	
-3.0m	Rear dozer up Rear dozer down Rear stab down 2 sets stab down Dozer and stab down	*7.0 *7.0 *7.0 *7.0 *7.0	4.6 5.4 *7.0 *7.0 *7.0	4.4 *4.9 *4.9 *4.9 *4.9	2.4 2.9 3.6 *4.9 4.6								*2.4 *2.5 *2.5 *2.5 *2.5		1.4 1.6 2.0 *2.5 *2.5	6.59	

## Stick Bucket

2.3 m 0.61 m<sup>3</sup>

Stick	Undercarriage configuration	3.0 m			4.5 m			m
		Upright	45°	90°	Upright	45°	90°	
6.0m	Rear dozer up Rear dozer down Rear stab down 2 sets stab down Dozer and stab down							
4.5m	Rear dozer up Rear dozer down Rear stab down 2 sets stab down Dozer and stab down							
3.0m	Rear dozer up Rear dozer down Rear stab down 2 sets stab down Dozer and stab down							
1.5m	Rear dozer up Rear dozer down Rear stab down 2 sets stab down Dozer and stab down							4.5 *5.8 *5.8
Ground	Rear dozer up Rear dozer down Rear stab down 2 sets stab down Dozer and stab down	*3.1 *3.1 *3.1 *3.1 *3.1	*3.1 *3.1 *3.1 *3.1 *3.1	4.3 *6.3 *6.3 *6.3 *6.3				
-1.5m	Rear dozer up Rear dozer down Rear stab down 2 sets stab down Dozer and stab down	*6.2 *6.2 *6.2 *6.2 *6.2	4.4 5.2 *6.2 *6.2 *6.2	4.2 *6.2 *6.2 *6.2 *6.2				*6.2 *6.2
-3.0m	Rear dozer up Rear dozer down Rear stab down 2 sets stab down Dozer and stab down	*7.6 *7.6 *7.6 *7.6 *7.6	4.5 5.4 7.0 *7.6 *7.8	4.3 *5.2 *5.2 *5.2 *5.2				*5.2 *5.2

## Stick Bucket

2.6 m 0.61 m<sup>3</sup>















Stick	Undercarriage configuration	3.0 m			4.5 m			m
		Upright	45°	90°	Upright	45°	90°	
6.0m	Rear dozer up Rear dozer down Rear stab down 2 sets stab down Dozer and stab down							
4.5m	Rear dozer up Rear dozer down Rear stab down 2 sets stab down Dozer and stab down							
3.0m	Rear dozer up Rear dozer down Rear stab down 2 sets stab down Dozer and stab down	*6.8 *6.8 *6.8 *6.8 *6.8	5.3 6.2 *6.8 *6.8 *6.8	*4.5 *4.5 *4.5 *4.5 *4.5				*4.5 *4.5
1.5m	Rear dozer up Rear dozer down Rear stab down 2 sets stab down Dozer and stab down							4.5 *5.6 *5.6
Ground	Rear dozer up Rear dozer down Rear stab down 2 sets stab down Dozer and stab down	*3.3 *3.3 *3.3 *3.3 *3.3	*3.3 *3.3 *3.3 *3.3 *3.3	4.3 *6.2 *6.2 *6.2 *6.2				
-1.5m	Rear dozer up Rear dozer down Rear stab down 2 sets stab down Dozer and stab down	*5.8 *5.8 *5.8 *5.8 *5.8	4.3 5.2 *5.8 *5.8 *5.8	4.2 *6.2 *6.2 *6.2 *6.2				*6.2 *6.2
-3.0m	Rear dozer up Rear dozer down Rear stab down 2 sets stab down Dozer and stab down	*8.1 *8.1 *8.1 *8.1 *8.1	4.4 5.3 6.9 *8.1 *8.1	4.2 *5.5 *5.5 *5.5 *5.5				*5.5 *5.5
-4.5m	Rear dozer up Rear dozer down Rear stab down 2 sets stab down Dozer and stab down	*8.0 *8.0 *8.0 *8.0 *8.0	4.8 5.7 7.3 *8.0 *8.0					

**Stick** **Bucket**  
3.0 m 0.54 m<sup>3</sup>

All weights are in metric tons

6.0 m			7.5 m						m
*2.4	*2.4	1.8							
*2.4	*2.4	2.1							
*2.4	*2.4	2.4							
*2.4	*2.4	2.4							
3.0	*3.4	1.8							
*3.4	*3.4	2.1							
*3.4	*3.4	2.5							
*3.4	*3.4	3.2							
3.0	*3.4	1.8							
*3.4	*3.4	2.1							
*3.4	*3.4	2.5							
*3.4	*3.4	3.2							
2.5	2.8	1.6				*1.4		1.0	8.30
3.0	*4.3	1.9				*1.4		1.1	
3.7	4.1	2.4				*1.4		1.4	
5.8	*4.3	3.6				*1.4		1.4	
4.7	*4.3	3.0				*1.4		1.4	
2.4	2.8	1.6				*1.5		0.9	8.22
2.8	*4.6	1.8				*1.5		1.1	
3.5	4.0	2.3				*1.5		1.4	
5.6	*4.6	3.6				*1.5		1.5	
4.5	*4.6	2.9				*1.5		1.5	
2.4	2.7	1.5				*1.8		1.0	7.79
2.8	*4.4	1.8				*1.8		1.2	
3.5	4.0	2.3				*1.8		1.5	
5.6	*4.4	3.5				*1.8		1.8	
4.5	*4.4	2.9				*1.8		1.8	
2.4						*2.1		1.3	6.95
2.8						*2.1		1.5	
3.5						*2.1		1.8	
*5.2						*2.1		2.1	
4.5						*2.1		2.1	

6.0 m			7.5 m						m
*2.5	*2.5	1.8							
*2.5	*2.5	2.1							
*2.5	*2.5	2.5							
*2.5	*2.5	2.5							
3.0	*3.0	1.8							
*3.0	*3.0	2.1							
*3.0	*3.0	2.6							
*3.0	*3.0	3.0							
2.8	2.9	1.7	2.0	1.1	*1.2			1.0	8.34
3.2	*3.7	2.0	*2.3	1.3	*1.2			1.1	
4.0	3.7	2.5	*2.3	1.7	*1.2			1.2	
*4.5	*3.7	*2.3	*2.3	*1.2	*1.2			1.2	
*4.5	*3.7	3.1	*2.3	2.1	*1.2			1.2	
2.5	2.8	1.6	2.0	1.1	*1.3			0.9	8.58
3.0	*4.2	1.9	*2.8	1.3	*1.3			1.0	
3.7	4.1	2.4	2.8	1.6	*1.3			1.3	
*5.6	*4.2	3.6	*2.8	2.5	*1.3			1.3	
4.7	*4.2	3.0	*2.8	2.1	*1.3			1.3	
2.4	2.7	1.5	1.9	1.0	*1.3			0.9	8.50
2.8	*4.5	1.8	*2.4	1.2	*1.3			1.0	
3.5	4.0	2.3	*2.4	1.6	*1.3			1.3	
5.6	*4.5	3.5	*2.4	2.0	*1.3			1.3	
4.5	*4.5	2.9	*2.4	2.0	*1.3			1.3	
2.3	2.7	1.5			*1.5			0.9	8.10
2.7	*4.4	1.8			*1.5			1.1	
3.4	3.9	2.3			*1.5			1.4	
5.5	*4.4	3.5			*1.5			1.5	
4.4	*4.4	2.8			*1.5			1.5	
2.3	2.7	1.5			*1.9			1.1	7.30
2.8	*3.6	1.8			*1.9			1.3	
3.5	*3.6	2.3			*1.9			1.7	
*5.5	*3.6	3.5			*1.9			1.9	
4.5	*3.6	2.9			*1.9			1.9	

	Undercarriage configuration	3.0 m			4.5 m			6.0 m			7.5 m						m
																	
6.0 m	Rear dozer up Rear dozer down Rear stab down 2 sets stab down Dozer and stab down							*2.3	*2.3	1.9							
4.5 m	Rear dozer up Rear dozer down Rear stab down 2 sets stab down Dozer and stab down							*2.6	*2.6	1.9	*1.6	1.2	*1.6	1.4	*1.6		
3.0 m	Rear dozer up Rear dozer down Rear stab down 2 sets stab down Dozer and stab down				*4.0	2.9	3.0	3.0	*3.3	1.8	2.0	1.2	*1.1	1.4	*1.1	0.9	
1.5 m	Rear dozer up Rear dozer down Rear stab down 2 sets stab down Dozer and stab down	*5.0	*5.0	4.7	4.5	2.6	2.9	2.9	*4.0	1.7	2.0	1.1	*1.1	1.3	*1.1	0.8	
Ground	Rear dozer up	*4.1	*4.1	*4.1	4.3	2.4	2.8	2.8	*4.4	1.6	1.9	1.1	*1.2	1.3	*1.2	0.8	
	Rear dozer down	*4.1	*4.1	*4.1	*6.1	2.8	3.5	3.5	4.0	2.3	*3.0	1.3	1.6	1.6	*1.2	1.0	
	Rear stab down	*4.1	*4.1	*4.1	*6.1	3.8	4.6	4.6	*4.4	2.4	*3.0	1.6	2.5	*1.2	*1.2	1.2	
	2 sets stab down Dozer and stab down	*4.1	*4.1	*4.1	*6.1	5.7	4.6	4.6	*4.4	3.6	*3.0	2.5	*1.2	*1.2	*1.2	*1.2	
-1.5 m	Rear dozer up Rear dozer down Rear stab down 2 sets stab down Dozer and stab down	*5.8	*5.8	4.3	4.2	2.3	2.7	2.7	*4.5	1.5		*1.4	*1.4	0.8	*1.4	1.0	
-3.0 m	Rear dozer up Rear dozer down Rear stab down 2 sets stab down Dozer and stab down	8.6	*8.7	4.4	4.2	2.3	2.7	2.7	*4.0	1.5		*1.7	*1.7	1.0	*1.7	1.2	
-4.5 m	Rear dozer up Rear dozer down Rear stab down 2 sets stab down Dozer and stab down	*6.1	*6.1	4.6	*3.9	2.5	2.9	2.9	*3.9								

\*\* all lift capacities are with optional 400 kg additional counterweight and optional heavy lift hydraulic circuit.



\* Limited by hydraulic rather than tipping load. The above loads are in compliance with hydraulic excavator lift capacity ratings standard ISO 10567, they do not exceed 87% of hydraulic lifting capacity or 75% of tipping capacity. Weight of all lifting accessories must be deducted from the above lifting capacities.

# Lift capacities\*\*

with hydraulically adjustable boom – 5.05 m

**Stick** **Bucket**  
1.6 m 0.68 m<sup>3</sup>

Stick	Undercarriage configuration	3.0 m			4.5 m			6.0 m			7.5 m			m
6.0 m	Rear dozer up Rear dozer down Rear stab down 2 sets stab down Dozer and stabdown				*3.8 *3.8 *3.8 *3.8	3.0 *3.8 3.4 *3.8								
4.5 m	Rear dozer up Rear dozer down Rear stab down 2 sets stab down Dozer and stab down				*4.3 *4.3 *4.3 *4.3	3.0 3.4 *4.1 *4.3	3.0 *3.7 *3.7		1.7 2.0 2.5 *3.7					
3.0 m	Rear dozer up Rear dozer down Rear stab down 2 sets stab down Dozer and stab down				4.6 *5.3 *5.3 *5.3	2.9 3.3 4.0 *5.7	3.0 *4.0 *4.0		1.7 2.0 2.5 *3.7			2.0 *2.4 *2.4	1.1 1.3 1.6 *2.4	7.65
1.5 m	Rear dozer up Rear dozer down Rear stab down 2 sets stab down Dozer and stab down	*6.5 *6.5 *6.5 *6.5	5.3 6.0 *6.5 *6.5	4.6 *5.9 *5.9 *5.9	*2.9 *3.3 4.0 *5.7	2.9 *4.3 *4.3		1.7 1.9 2.4 3.1			1.8 *2.5 *2.5	1.0 1.2 1.5 *2.3	7.91	
Ground	Rear dozer up	*9.1	5.1	4.8	2.8	2.8		1.6			1.8	1.0	7.83	
	Rear dozer down		6.0	*6.2	3.2	*4.5		1.9			*2.6	1.1		
	Rear stab down	*9.1	7.6	*6.2	4.0	*4.5		2.3			*2.6	1.5		
	2 sets stab down	*9.1	*9.1	*6.2	5.8	*4.5		3.6			*2.6	2.3		
Dozer and stab down	*9.1	*9.1	*6.2	4.9	*4.1		3.0				1.9			
-1.5 m	Rear dozer up Rear dozer down Rear stab down 2 sets stab down Dozer and stab down	9.5 *10.3 *10.3 *10.3	5.0 5.9 7.6 *10.3	4.5 *6.4 *6.4 *6.4	2.6 3.0 3.8 *5.9	2.7 *4.2 *4.2 *4.2		1.5 1.8 2.2 3.5			2.0 *2.9 *2.9	1.1 1.3 1.6 2.6	7.38	
-3.0 m	Rear dozer up Rear dozer down Rear stab down 2 sets stab down Dozer and stab down	*9.3 *9.8 *9.8 *9.8	4.8 5.7 7.4 *9.8	4.4 *5.1 *5.1 *5.1	2.4 2.9 3.6 *5.1									

**Stick** **Bucket**  
2.0 m 0.61 m<sup>3</sup>

Stick	Undercarriage configuration	3.0 m			4.5 m			6.0 m			7.5 m			m
6.0 m	Rear dozer up Rear dozer down Rear stab down 2 sets stab down Dozer and stab down				*3.5 *3.5 *3.5 *3.5	3.1 *3.5 *3.5 *3.5	*2.9 *2.9 *2.9 *2.9		1.8 2.1 2.5 *2.9					
4.5 m	Rear dozer up Rear dozer down Rear stab down 2 sets stab down Dozer and stab down	*4.3 *4.3 *4.3 *4.3	4.3 4.3 4.3 4.3	*4.1 *4.1 *4.1 *4.1	*3.0 *3.4 *4.1 *4.1	3.1 *3.5 *3.5 *3.5		1.8 2.1 2.6 *3.5						
3.0 m	Rear dozer up Rear dozer down Rear stab down 2 sets stab down Dozer and stab down	*5.9 *5.9 *5.9 *5.9	5.4 *5.9 *5.9 *5.9	4.7 *5.1 *5.1 *5.1	3.0 3.4 *4.0 *5.1	3.1 *3.9 *3.9 *3.9		1.8 2.1 2.6 *3.8			*1.6 *1.6 *1.6	1.0 1.2 1.5 *1.6	8.05	
1.5 m	Rear dozer up Rear dozer down Rear stab down 2 sets stab down Dozer and stab down	*6.6 *6.6 *6.6 *6.6	5.3 6.0 *6.6 *6.6	4.7 *5.9 *5.9 *5.9	3.0 *3.3 4.0 *5.8	3.0 *4.3 *4.3 *4.3		1.8 2.1 2.6 *3.8			*1.6 *1.6 *1.6	0.9 1.1 1.4 *1.6	8.30	
Ground	Rear dozer up	*9.1	5.2	4.8	2.8	2.9		1.7			*1.7	0.9	8.22	
	Rear dozer down		6.1	*6.3	3.3	*4.5		2.0			*1.7	1.1		
	Rear stab down	*9.1	7.6	*6.3	4.0	4.5		2.4			*1.7	1.4		
	2 sets stab down	*9.1	*9.1	*6.3	5.8	*4.5		3.2			*1.7	*1.7		
Dozer and stab down	*9.1	*9.1	*6.3	4.9	*4.2		3.1				*1.7			
-1.5 m	Rear dozer up Rear dozer down Rear stab down 2 sets stab down Dozer and stab down	9.5 *10.3 *10.3 *10.3	5.0 5.9 7.6 *10.3	4.6 *6.4 *6.4 *6.4	2.7 3.3 3.8 6.0	2.8 *4.5 4.1 *4.5		1.6 1.8 2.3 3.6			*1.8 *1.9 *1.9	1.0 1.2 1.5 *1.9	7.79	
-3.0 m	Rear dozer up Rear dozer down Rear stab down 2 sets stab down Dozer and stab down	9.5 *10.6 *10.6 *10.6	5.0 5.9 7.6 *10.6	4.5 *6.0 *6.0 *6.0	2.5 2.9 3.7 *5.9						*2.2 *2.2 *2.2	1.2 1.5 1.8 *2.2	6.95	

**Stick** **Bucket**  
2.3 m 0.54 m<sup>3</sup>

Stick	Undercarriage configuration	3.0 m			4.5 m	
6.0 m	Rear dozer up Rear dozer down Rear stab down 2 sets stab down Dozer and stab down				*3.1 *3.1 *3.1	*3.1 *3.1
4.5 m	Rear dozer up Rear dozer down Rear stab down 2 sets stab down Dozer and stab down	*3.0 *3.0 *3.0 *3.0	*3.0 *3.0 *3.0 *3.0	*3.5 *3.5 *3.5 *3.5	*3.5 *3.5	*3.5 *3.5
3.0 m	Rear dozer up Rear dozer down Rear stab down 2 sets stab down Dozer and stab down	*5.1 *5.1 *5.1 *5.1	*5.1 *5.1 *5.1 *5.1	*4.7 *4.8 *4.8 *4.8	*4.8 *4.8	*4.8 *4.8
1.5 m	Rear dozer up Rear dozer down Rear stab down 2 sets stab down Dozer and stab down	*6.9 *6.9 *6.9 *6.9	5.3 6.0 *6.9 *6.9	4.6 *5.8 *5.8 *5.8	*5.8 *5.8	*5.8 *5.8
Ground	Rear dozer up	*8.7	5.3	4.7		
	Rear dozer down		6.2	*6.2		
	Rear stab down	*8.7	*8.7	*6.2		
	2 sets stab down	*8.7	*8.7	*6.2		
-1.5 m	Rear dozer up Rear dozer down Rear stab down 2 sets stab down Dozer and stab down	*9.4 *10.2 *10.2 *10.2	5.0 6.0 7.6 *10.2	4.7 *6.3 *6.3 *6.3		
-3.0 m	Rear dozer up Rear dozer down Rear stab down 2 sets stab down Dozer and stab down	9.5 *10.7 *10.7 *10.7	5.0 6.0 7.6 *10.7	4.5 *6.3 *6.3 *6.3		

**Stick** **Bucket**  
2.6 m 0.54 m<sup>3</sup>

Stick	Undercarriage configuration	3.0 m			4.5 m	
6.0 m	Rear dozer up Rear dozer down Rear stab down 2 sets stab down Dozer and stab down				*2.7 *2.7 *2.7	*2.7 *2.7
4.5 m	Rear dozer up Rear dozer down Rear stab down 2 sets stab down Dozer and stab down				*3.0 *3.0 *3.0	*3.0 *3.0
3.0 m	Rear dozer up Rear dozer down Rear stab down 2 sets stab down Dozer and stab down	*5.3 *5.3 *5.3 *5.3	*5.3 *5.3 *5.3 *5.3	*4.6 *4.6 *4.6 *4.6		
1.5 m	Rear dozer up Rear dozer down Rear stab down 2 sets stab down Dozer and stab down	*7.0 *7.0 *7.0 *7.0	5.2 6.1 *7.0 *7.0	4.6 *5.6 *5.6 *5.6		
Ground	Rear dozer up	*8.1	5.3	4.6		
	Rear dozer down		6.1	*6.1		
	Rear stab down	*8.1	*8.1	*6.1		
	2 sets stab down	*8.1	*8.1	*6.1		
-1.5 m	Rear dozer up Rear dozer down Rear stab down 2 sets stab down Dozer and stab down	9.2 *10.0 *10.0 *10.0	5.0 5.9 7.6 *10.0	4.7 *6.3 *6.3 *6.3		
-3.0 m	Rear dozer up Rear dozer down Rear stab down 2 sets stab down Dozer and stab down	9.5 *10.4 *10.4 *10.4	5.0 5.9 7.6 *10.4	4.5 *6.5 *6.5 *6.5		
-4.5 m	Rear dozer up Rear dozer down Rear stab down 2 sets stab down Dozer and stab down	*8.0 *8.0 *8.0 *8.0	4.8 5.7 7.3 *8.0			

**Stick Bucket**  
3.0 m 0.40 m<sup>3</sup>

All weights are in metric tons

m	6.0m				7.5m					
*3.1	*3.0									
*3.1	*3.0									
*3.1	*3.0									
*3.1	*3.0									
3.1	3.1									
*3.5	*3.4									
*3.5	*3.4									
*3.5	*3.4									
*3.5	*3.4									
3.0	3.1									8.35
*3.4	*3.8									
4.0	3.8									
*4.8	*3.8									
*4.8	*3.8									
2.9	3.1									8.59
3.3	*4.2									
4.0	*4.1									
*5.8	*4.2									
4.9	*4.2									
2.9	3.0									8.51
3.3	*4.5									
4.0	4.2									
5.8	*4.5									
4.9	*4.5									
2.7	2.8									8.11
3.2	*4.5									
3.9	4.1									
6.0	*4.5									
5.0	*4.5									
2.5	2.8									7.31
3.0	*3.4									
3.7	*3.4									
*5.9	*3.4									
4.7	*3.4									

m	Undercarriage configuration	3.0m			4.5m			6.0m			7.5m				
6.0m	Rear dozer up Rear dozer down Rear stab down 2 sets stab down Dozer and stab down							*2.4	*2.4	2.0					
4.5m	Rear dozer up Rear dozer down Rear stab down 2 sets stab down Dozer and stab down				*2.5	*2.5	*2.5	*2.5	*2.7	2.0	*2.1	1.2			
3.0m	Rear dozer up Rear dozer down Rear stab down 2 sets stab down Dozer and stab down	*5.4	*5.4	*5.4	*4.3	*4.3	*4.3	3.0	3.1	*3.4	1.9	*2.1	1.2	*1.1	0.9
1.5m	Rear dozer up Rear dozer down Rear stab down 2 sets stab down Dozer and stab down	*7.0	*7.0	5.2	4.6	*5.4	2.9	3.0	*4.0	1.9	2.1	*3.3	*1.1	*1.1	0.8
Ground	Rear dozer up Rear dozer down Rear stab down 2 sets stab down Dozer and stab down	*8.2	*8.2	6.0	6.1	*6.1	*3.9	4.0	*4.1	*2.1	2.6	*3.2	1.3	*1.2	0.9
-1.5m	Rear dozer up Rear dozer down Rear stab down 2 sets stab down Dozer and stab down	9.1	*9.7	5.1	4.8	*6.2	2.8	2.9	*4.5	1.7	1.9	*2.9	1.0	*1.3	0.8
-3.0m	Rear dozer up Rear dozer down Rear stab down 2 sets stab down Dozer and stab down	9.5	*10.3	5.0	4.5	*6.4	2.6	2.8	*4.3	1.6			*1.6	*1.6	0.9
-4.5m	Rear dozer up Rear dozer down Rear stab down 2 sets stab down Dozer and stab down	*9.2	*9.3	4.8	4.4	*4.9	2.5	2.9	*4.9	3.6					

m	6.0m				7.5m					
*2.7	*2.8									
*2.7	*2.8									
*2.7	*2.8									
*2.7	*2.8									
*2.7	*2.8									
*3.0	*3.1									
*3.0	*3.1									
*3.0	*3.1									
*3.0	*3.1									
3.0	3.0									8.65
3.3	*3.6									
4.0	*3.6									
*4.6	*3.6									
*4.6	*3.6									
2.9	3.0									8.88
3.3	*4.1									
*3.9	*4.1									
*5.6	*4.1									
4.8	*4.1									
2.9	3.0									8.80
*3.3	*4.4									
4.0	4.1									
5.7	*4.4									
*4.8	*4.4									
2.7	2.8									8.42
3.2	*4.5									
3.9	4.1									
*5.9	*4.5									
5.0	*4.5									
2.5	2.7									7.66
2.9	*3.9									
3.7	*3.9									
5.9	*3.9									
4.7	*3.9									

\*\* all lift capacities are with optional additional counterweight and optional heavy lift hydraulic circuit.

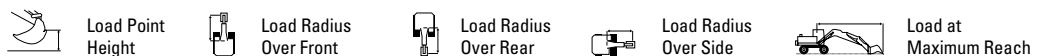

\* Limited by hydraulic rather than tipping load. The above loads are in compliance with hydraulic excavator lift capacity ratings standard ISO 10567, they do not exceed 87% of hydraulic lifting capacity or 75% of tipping capacity. Weight of all lifting accessories must be deducted from the above lifting capacities.

## Standard equipment

The M312 is a worldwide model from Caterpillar. To provide you with the optimum configuration for your jobs, standard and optional equipment may vary. Please ask your Cat dealer for the latest equipment list for your country.

Adjustable pilot operated joystick type lever controls	Roading lights including headlights, taillights and turning lights	Lockable oscillating front axle
Alternator, 55-amp.	Suspension seat with: adjustable armrests, lumbar support and retractable seat belt	Power mode selector, economy and standard
Automatic engine speed control (AEC)	Warning horn	One-piece drive-shaft
Batteries, 2 Caterpillar	Cat 3054 TA diesel engine, emission controlled, 85 kW at 2000 rpm	Openable two piece front windshield and openable skylight
Cab with:	24 Volt electric starting	Parking brake
Ash tray and lighter	2300 m altitude capacity	Prepared for optional pin-on dozer blade and/or outriggers for front and/or rear installation
Bottle holder	Downshift inhibitor	Positive filtered ventilation, 3 speed
Coat hook	Dual tires 10.00-20	Rearview mirror, left and right
Cooler box behind operators seat	Electronic Power Control Unit with backup system	Steering column, tiltable
Floor mat	Fully hydraulic braking system	Swing brake, automatic
Glass, tempered and tinted, EC approved, pressurized and sound suppressed	Full hydraulic steering with emergency steering capability	Variable displacement, load sensing hydraulic system
Heater and defroster	Hydraulic maximum speed limiter	Wide steps on both sides
Hydraulic lock, left side console activated	Hydrostatic drive 2 speed, 4 wheel drive with on-the-go shifting	Wiper and washer
Interior lighting		
Literature compartment		

## Optional equipment

Additional counterweight, 400 kg	Check valves	Refuelling pump, electric
Air conditioner	Boom cylinders	Rotating beacon
Air horn	Stick cylinder	Spacer rings, rubber, for use between dual tires
Air suspension seat	VA cylinder	Sticks
Alarm, back-up	Clamshell restraint	1600 mm
Anti-drift valve	Dozer blade, front or rear mounted	2000 mm
For VA boom cylinder	Guards	2300 mm
For stick cylinder	Cab roof (FOPS)	2600 mm
For bucket cylinder	Front window	3000 mm
Auxiliary hydraulic circuits (AHC):	Vandalism protection	2800 mm material handling
Medium pressure circuit for booms and sticks	Headrest for driver's seat	Sound suppression screen
High pressure circuit for booms and sticks	Heavy lift arrangement	Sun blinds
Hammer circuit for booms and sticks	Lights	For polycarbonate skylight
Biodegradable hydraulic oil	Warning, stick mounted	For rear windscreen
Booms	Working for all booms	For right side windscreen
One piece boom	Working, front, cab mounted (2x)	Supplemental steering
Hydraulically adjustable (VA)	Working, rear, cab mounted (1x)	Tilting device (for ditch cleaning buckets only)
Offset VA boom	Outriggers, pin-on, individually controlled	Tires
Buckets	1 set, front or rear mounted	Tip groups
Bucket linkage	2 sets, front and rear mounted	Tool box, left and/or right undercarriage-mounted
With diverter valve	Overload warning device	Travel speed lock
Without diverter valve	Rain protective shade for front windscreen	Two-piece drive-shaft
Cab, deluxe (openable side window)	Radio Mounting Kit with loudspeakers and antenna (does not include radio)	Wiper and washer for lower front windscreen
Cab riser, 1.2 m, fixed	Radio (includes Radio Mounting Kit)	

## Cat '5-Star Customer Service'

*Purchase a Cat M312. You know it's 'equipped' with something unique and dependable – Cat '5-Star Customer Service' as delivered by your Cat dealer.*

**Cat '5-Star Customer Service' means peace of mind from the minute you contact your Cat dealer.** By building a partnership with your Cat dealer, you can focus on your business instead of your equipment. Cat '5-Star Customer Service' brings together all the products, services and people from Caterpillar and the Cat dealer network and puts them firmly behind you. Count on them to help you maintain your competitive edge.

**Cat '5-Star Customer Service' includes Equipment Management Services to help you make a better business decision.** We'll assist you in selecting the right Cat equipment to suit your need, to optimize productivity. And we'll help you make smarter decisions, assist you with machine selection, purchasing or renting options, financing, and projected owning and operating costs.

**Maintenance Services that enable you to maximize machine availability and performance.** Every Cat dealer has a wide choice of maintenance products and services to make sure your equipment achieves maximum performance for the lowest possible cost.

**Predictive Services to anticipate problems.** By anticipating potential problems and preventing unscheduled repairs, Cat Predictive Services make sure that your equipment is always up and ready to run – because maximizing uptime means maximum earning capacity.



### **Reconditioning Services for a wider choice of repair alternatives.**

Caterpillar factory-reconditioned parts and components get your equipment back on the job in the minimum of time and with lower repair costs, contributing to reduced operating costs and a more efficient operation.

**Off-the shelf availability of genuine Cat parts.** Genuine parts, together with highly experienced, Cat-trained specialists make sure every repair is right first time and your machine is back earning its keep in the shortest possible time.



**"Cat 5-Star Customer Service is our commitment to provide you with the best equipment and services for the most cost effective solutions in your business."**

Caterpillar and Cat dealers

# M312 Wheel Excavator

HEHH2052-1 (04/2000) hr

Featured photos of machines may not always include standard equipment.  
See your Caterpillar Dealer for available options.  
Materials and specifications are subject to change without notice.

[www.CAT.com](http://www.CAT.com)

© 2000 Caterpillar

**CATERPILLAR**<sup>®</sup>